

# Basic Science: Biomechanics

Paul Banaszekiewicz

# Outline

- What is biomechanics?
- Units of measure
- Newton's laws of motion
- Free body diagrams
- Moments
- Kinematics
- Gait analysis
- Example: Hip OA and arthroplasty
- Example: Knee instability

# What is biomechanics?

- Biomechanics – study of the mechanics of living things
- Orthopaedic biomechanics is interested in:
  - Joint function
    - prosthesis design
  - Mechanics of bones
  - Soft tissue mechanics/function
  - Whole body function
- We measure movement, forces and muscle actions

# Newton's laws

- **Law 1: Inertia - sum of forces = 0**
  - Every object in a state of uniform motion tends to remain in that state of motion unless an external force is applied to it
- **Law 2: Acceleration**
  - The relationship between an object's mass  $m$ , its acceleration  $\mathbf{a}$ , and the applied force  $\mathbf{F}$  is  $\mathbf{F} = m\mathbf{a}$
- **Law 3: Reactions – free body analysis**
  - For every action there is an equal and opposite reaction



## Question: What is a force?

- A force is a **load acting on a structure** or object.
- It can be either a push (**compressive** force) or a pull (**tensile** force).
- Forces can either be **external** to the body (e.g. ground reaction forces, gravity, etc.) or **internal** to the body (e.g. joint contact forces, muscle contractile forces, ligamentous constraint forces).
- **Forces are vectors**, such that they have both magnitude and direction. Forces can therefore be resolved into their components in the x, y and z axes using Pythagoras' theorem.

# Force

- Force is measured in Newtons
  - For body weight (a force)
    - Force (in Newtons) =  $9.81 \times \text{mass (in kg)}$
    - $9.81 \text{ m/s/s}$  is acceleration due to gravity if on earth's surface





Question: What do you understand by the term “free body diagram”?

- This is a method used to **illustrate the various forces** acting on a structure such as a bone, and to illustrate **how far from a joint** or other pivot point these forces are acting. From knowing these forces and distances, the **moments of force** acting to maintain the structure in **static equilibrium** can be calculated.

# Free body diagrams

- Simplified representation of system
- Illustrate locations and directions of forces
- Illustrate distances (perpendicular) from joint to line of action of force

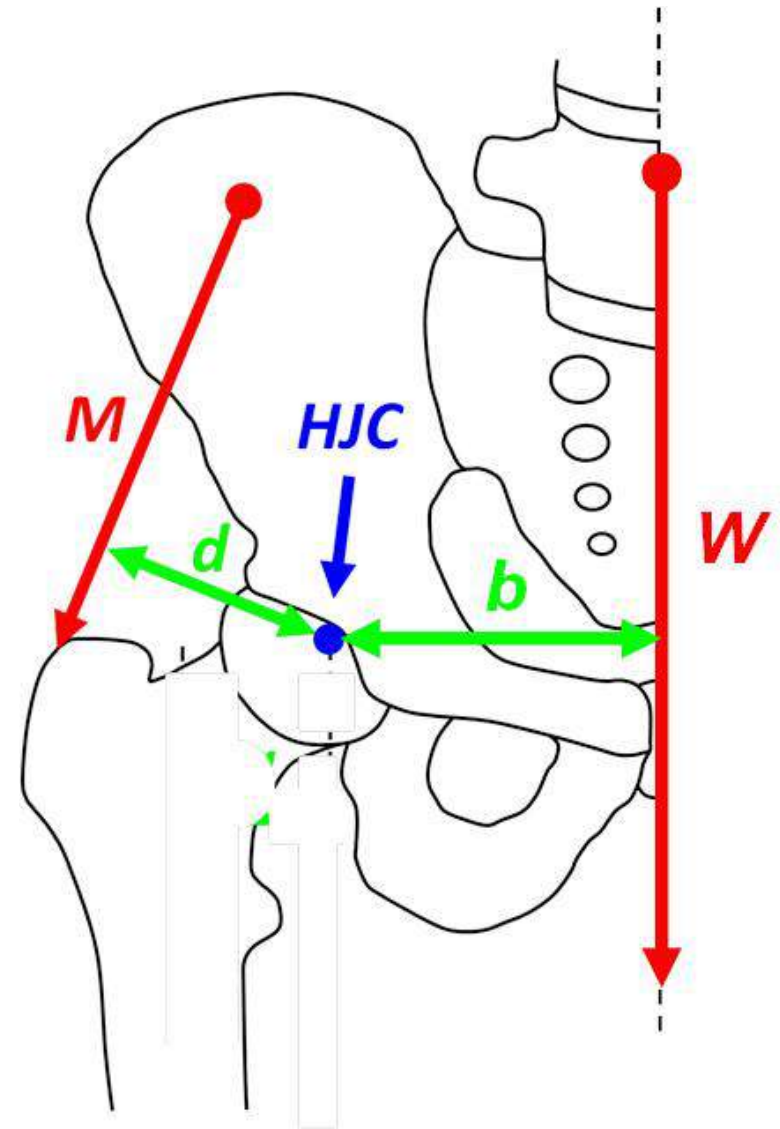



# Question: What are the assumptions made when drawing a free body diagram

- Bones are rigid bodies
- Joints are frictionless hinges
- No antagonistic muscle action
- Weight of body is concentrated at the exact centre of body mass
- Internal forces cancel each other out
- Muscles only act in tension
- The line of action of a muscle is along the centre of cross-sectional area of muscle mass
- Joint reaction forces are assumed to be only compressive.

# Scalars and Vectors

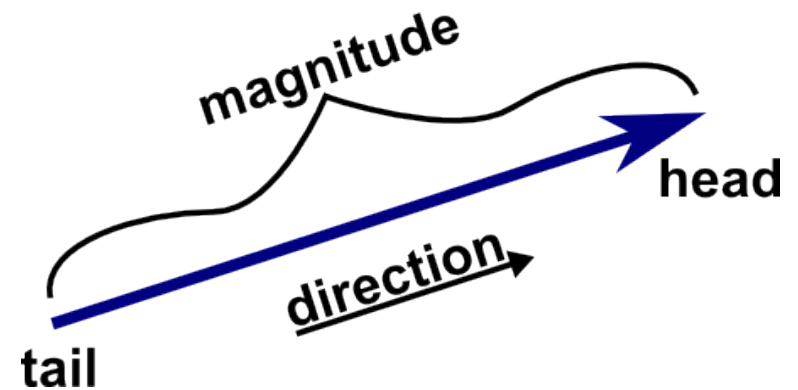

- Scalar quantities
  - have only magnitude
  - Completely specified by a number of appropriate units
- For example - length, area, volume, speed and mass
- Vector quantities
- Have magnitude and direction
- Can be added, subtracted or split into components

# Vector resolution

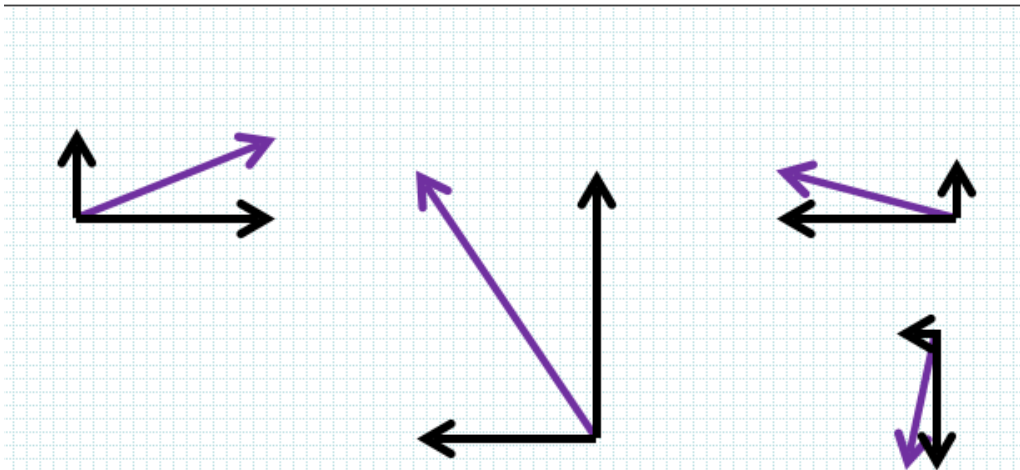
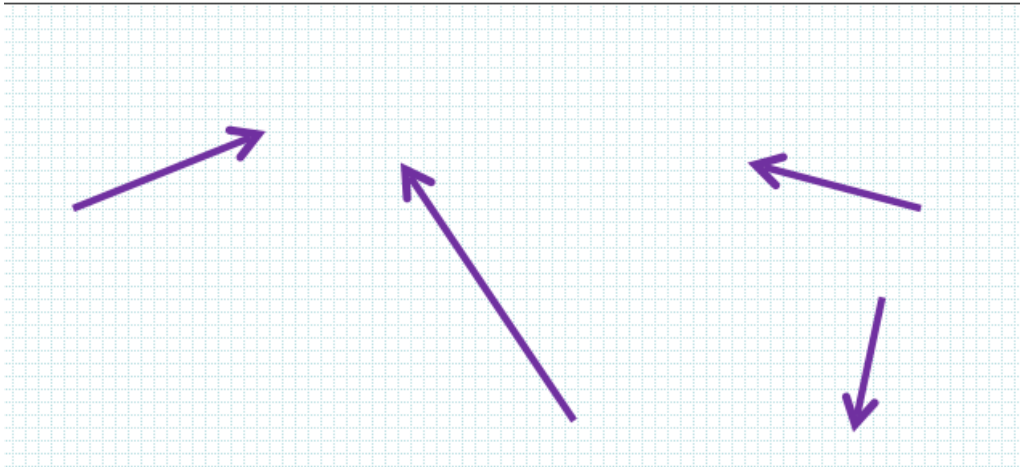

- Vector resolution methods
  - Graph paper
    - Draw vectors to scale
  - Maths (Pythagoras, trigonometry)

SCALE: 1 cm = 1 m/s

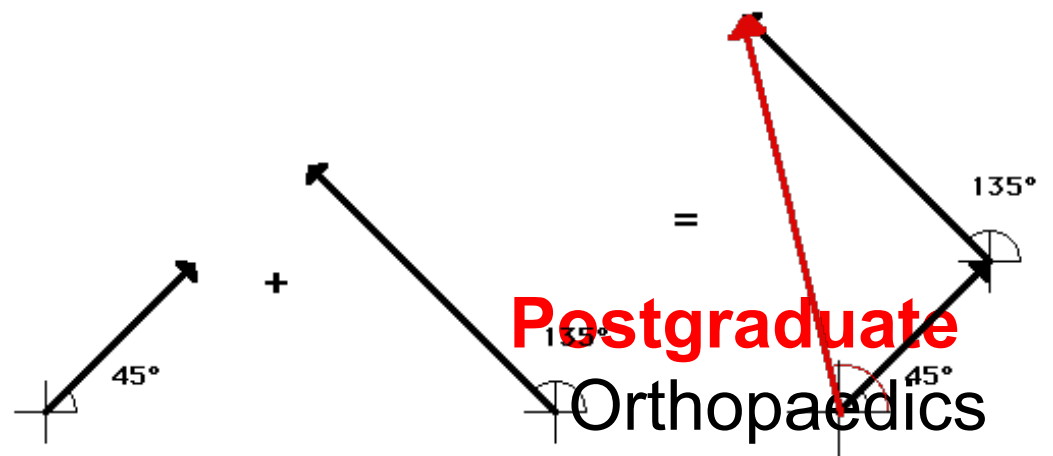

# Parallelogram law

- Vector **P** and **Q** are drawn from same origin.
- Straight lines are drawn parallel to both vectors so as to form a parallelogram.
- The resultant (**P+Q**) is represented by the diagonal of the parallelogram that passes through the origin.

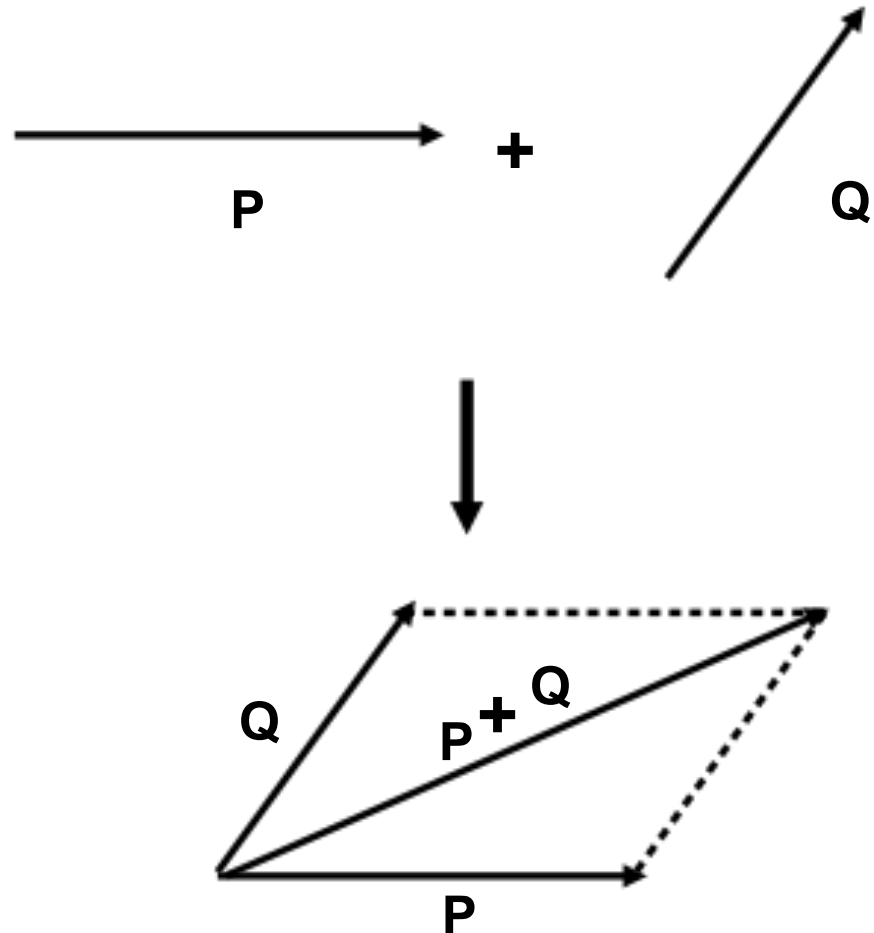



## Question: What is a moment?

- A moment is generated as a result of a **force acting at a distance** away from a pivot point or joint.
- For example, the **muscles acting about a joint**, with their origins/insertions at a distance away from the joint, will act to **generate a turning moment** about that joint that can either act to keep the joint in static equilibrium - by balancing all the moments generated by the agonist and antagonist muscles – or to generate rotation about the joint – as a result of moments on one side of the joint being greater than on the other side of the joint.

# Moments

- Force applied at distance from pivot will cause segment to rotate
  - Distance is called the moment arm
  - Rotational effect is called turning moment
  - Turning moment = force x moment arm
  - Also known as torque

# Examples

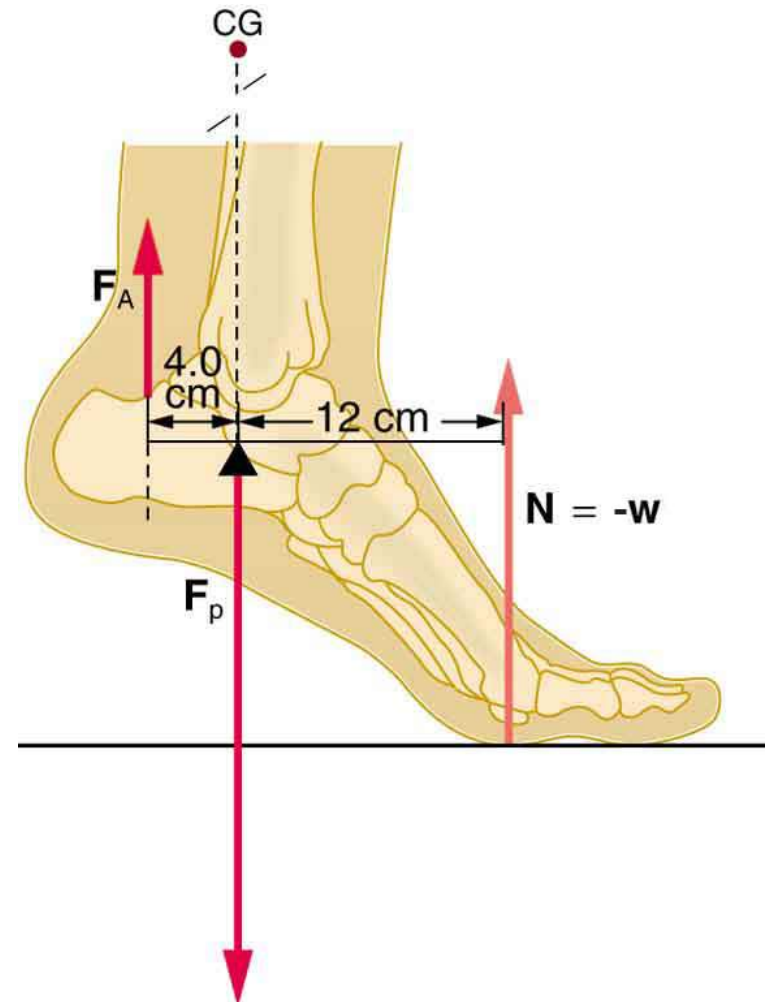
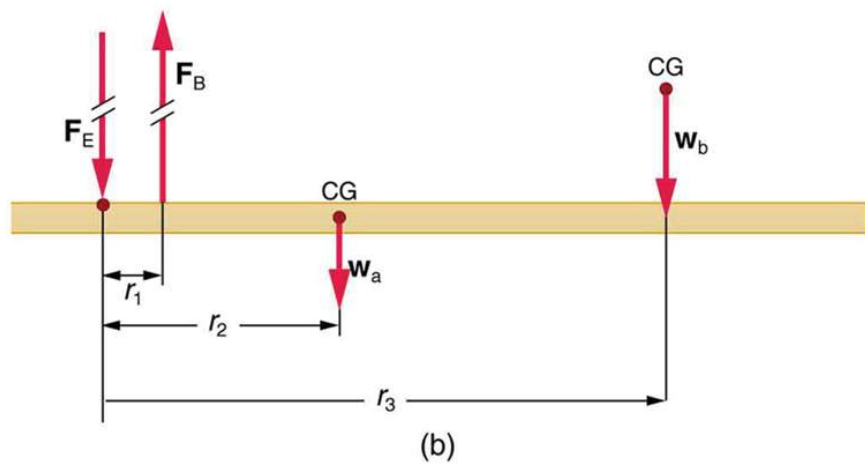
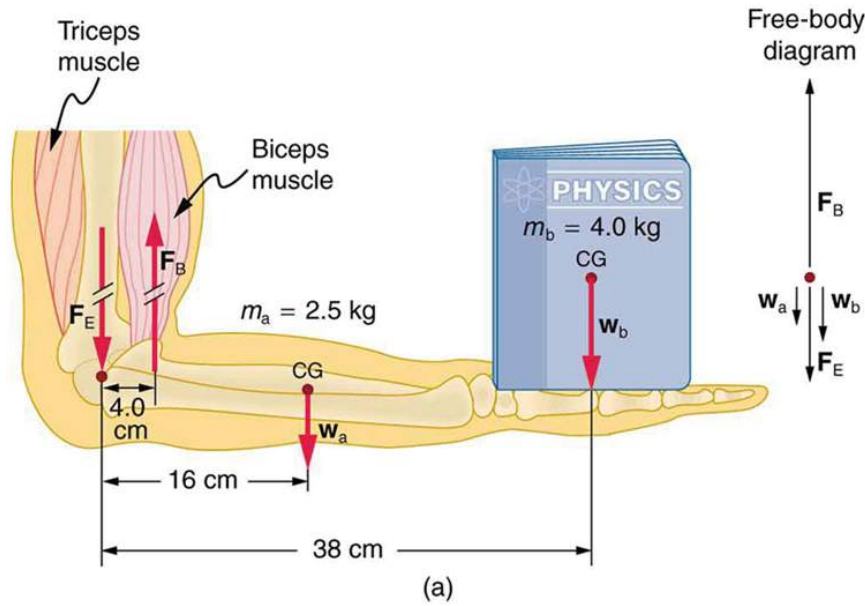

## POTENTIAL ANSWER

# Question: What is a lever?

- A lever is a rigid bar (bone) that turns about an axis of rotation or fulcrum(joint)
- The lever rotates about the axis as a result of a force(from muscle contracture)
- The force acts against a resistance(weight,gravity)
- Levers are used to alter the resulting direction of the applied force

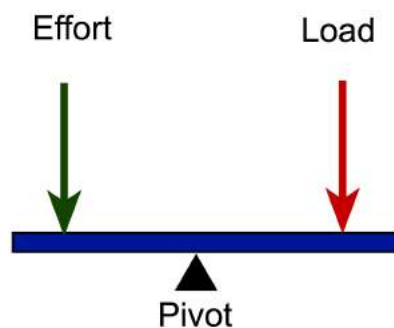

First Class  
Lever

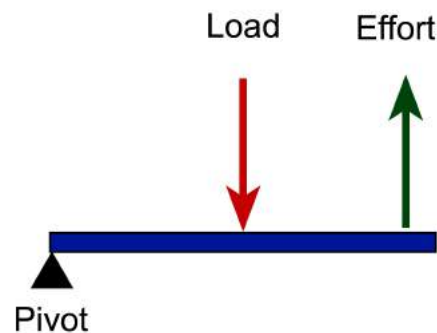

Second Class  
Lever

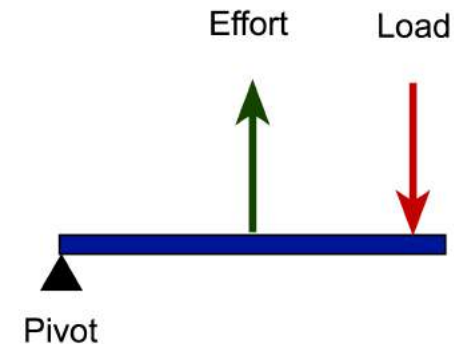

Third Class  
Lever

Class One Lever

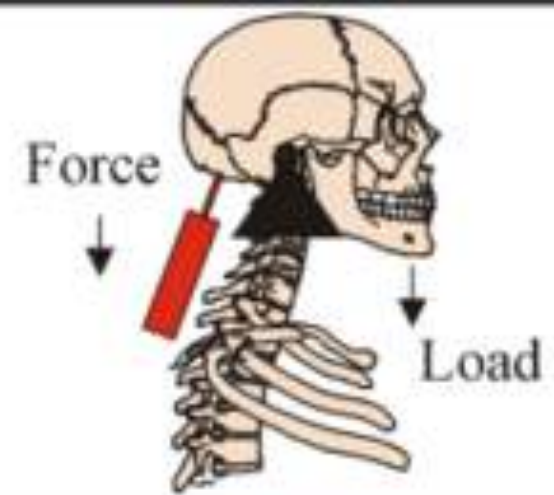
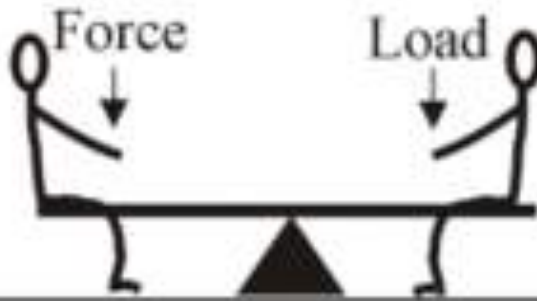

Class Two Lever

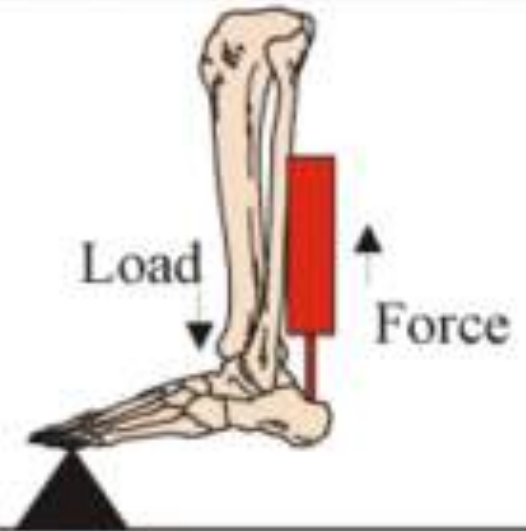
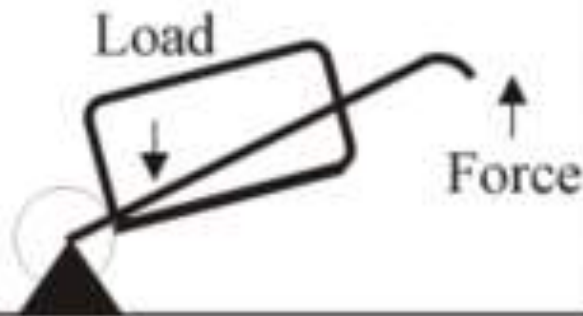
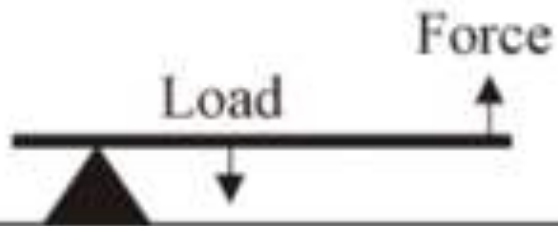

Class Three Lever

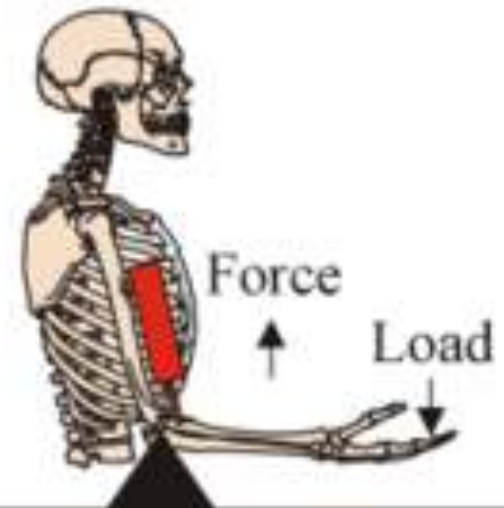
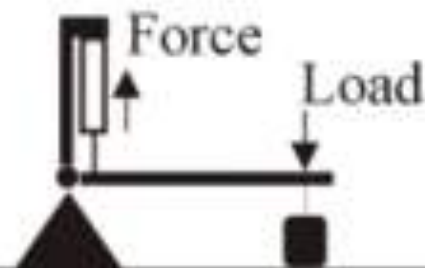
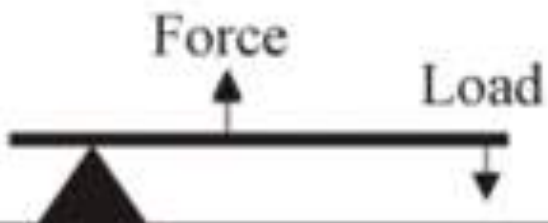

# Question: Can you draw a free body diagram of the elbow joint with an object in the hand?

## POTENTIAL ANSWER

- Arm, hand, fingers rigid segment
- 2D
- Arm is flexed  $90^\circ$
- Elbow is fulcrum for the forearm lever
- instantaneous axis of rotation (IAR)
- Entire mass of an object is considered to be concentrated at a point called the centre of mass (COM)
- Centre of gravity from which a weight is considered to act (COG)
- $COM = COG$

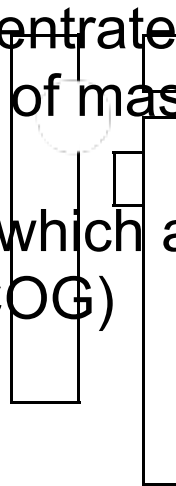
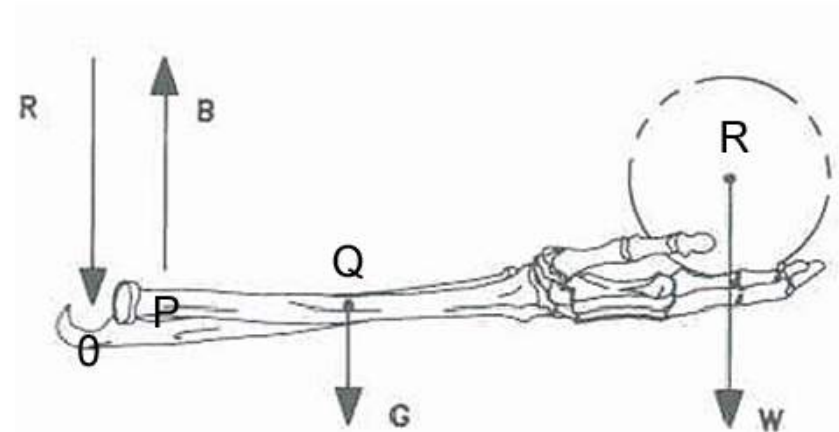
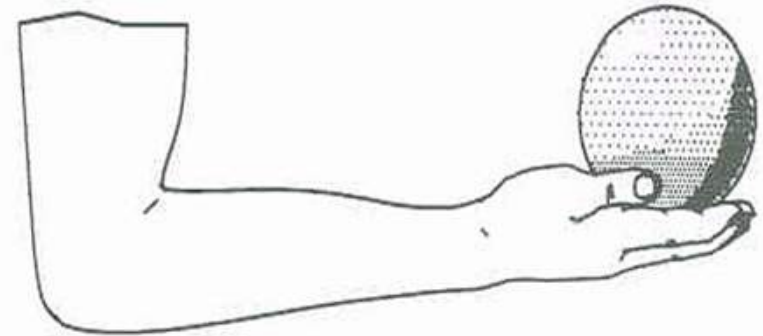

# Question: Can you draw a free body diagram of the elbow joint?

## POTENTIAL ANSWER

Forces acting on the free body include:

1. G- weight of the body acting vertically downwards 10N
2. W- Weight object 25N
3. B-Force acting through biceps muscle
4. R-Joint reaction force (JFR) acting between the ulna & humerus
5. Point O is the IAR of the elbow joint
6. Point P attachment of biceps on the radius
7. Q COG of the forearm
8. R lies on the vertical line passing through the COG of the weight held in the hand

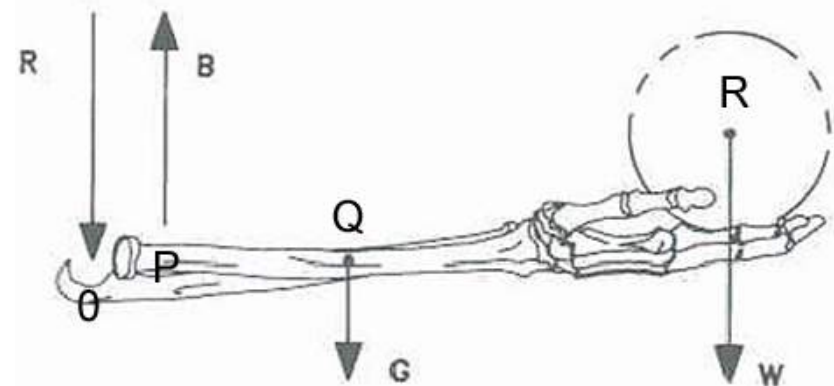
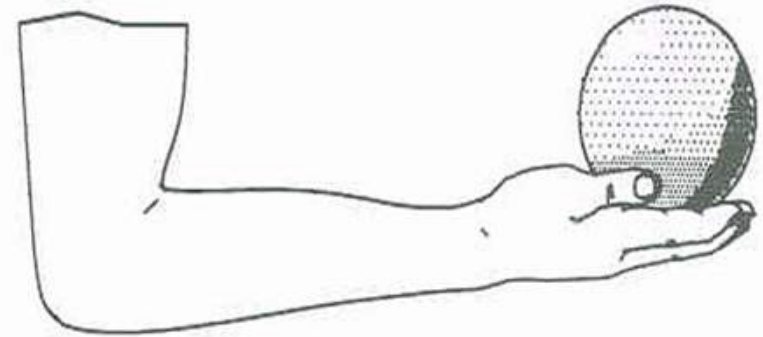

# Biceps force - Elbow flexion

- Sum clockwise (extension) and anticlockwise (flexion) moments about elbow = zero
- $\Sigma M=0$
- $0.05 \times \text{Biceps} = W \times 0.5 + G \times 0.2$
- $B \times 0.05 = 25\text{N} \times 0.5 + 10\text{N} \times 0.2$
- $0.05B = 12.5 + 2$
- $B = 290\text{N}$

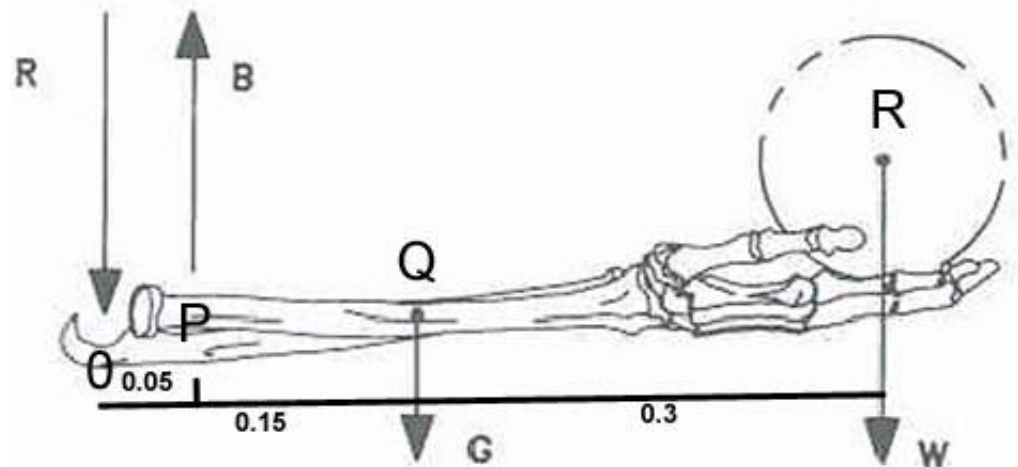

# Joint reaction force - Elbow flexion

- $\Sigma F=0$
- $R = B - G - W$
- $R = 290 - 10 - 25$
- $R = 255 \text{ N}$

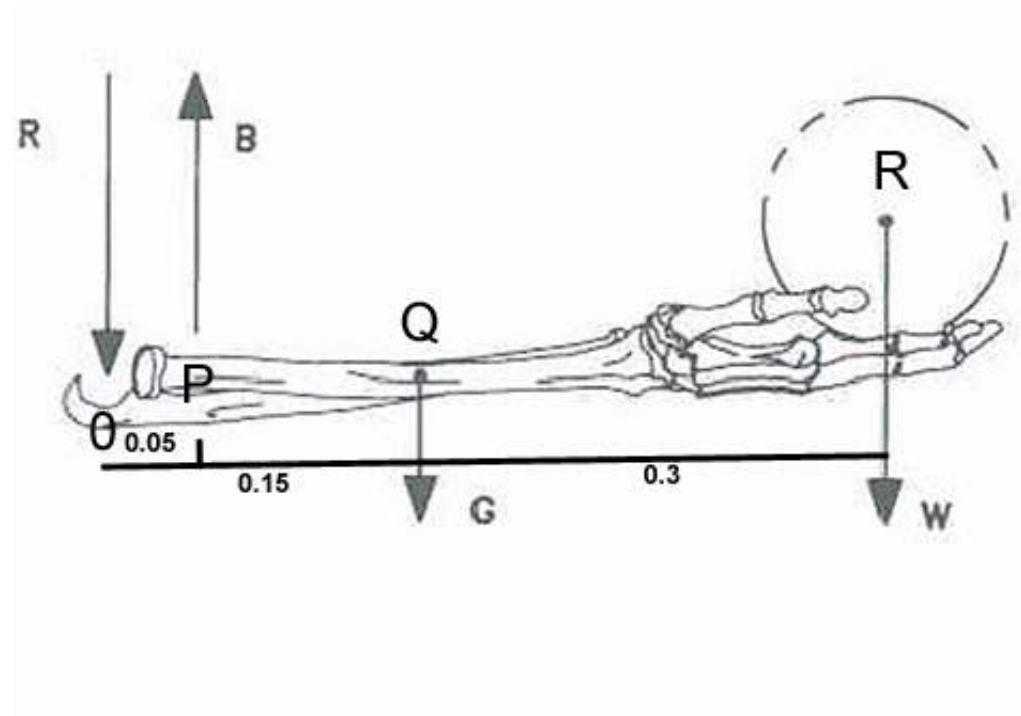
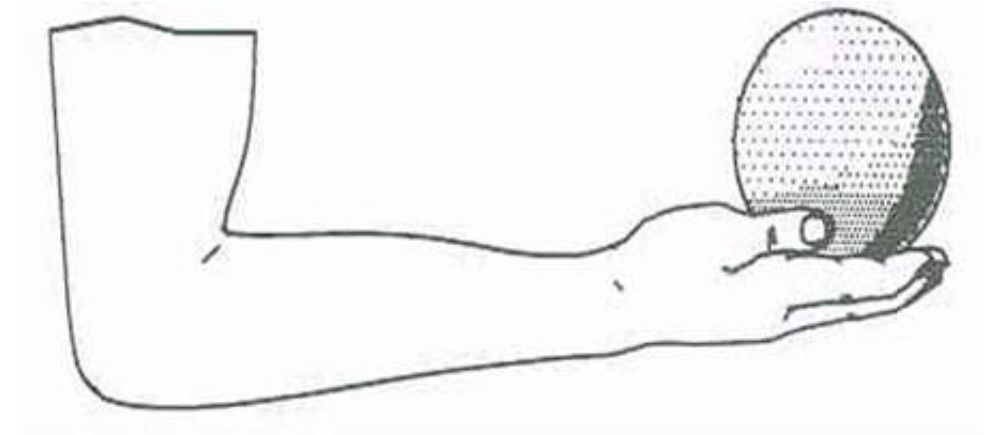

# Hip Biomechanics

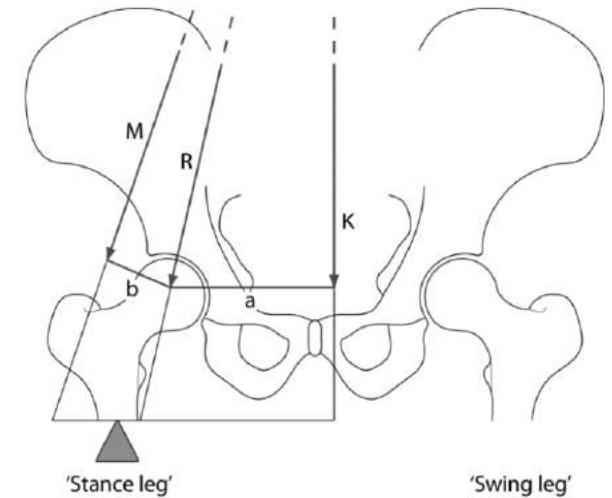
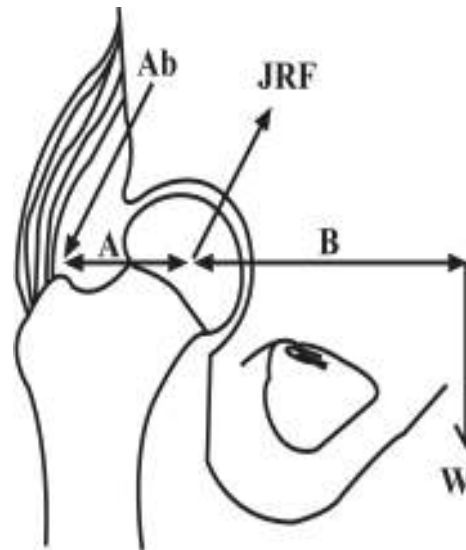
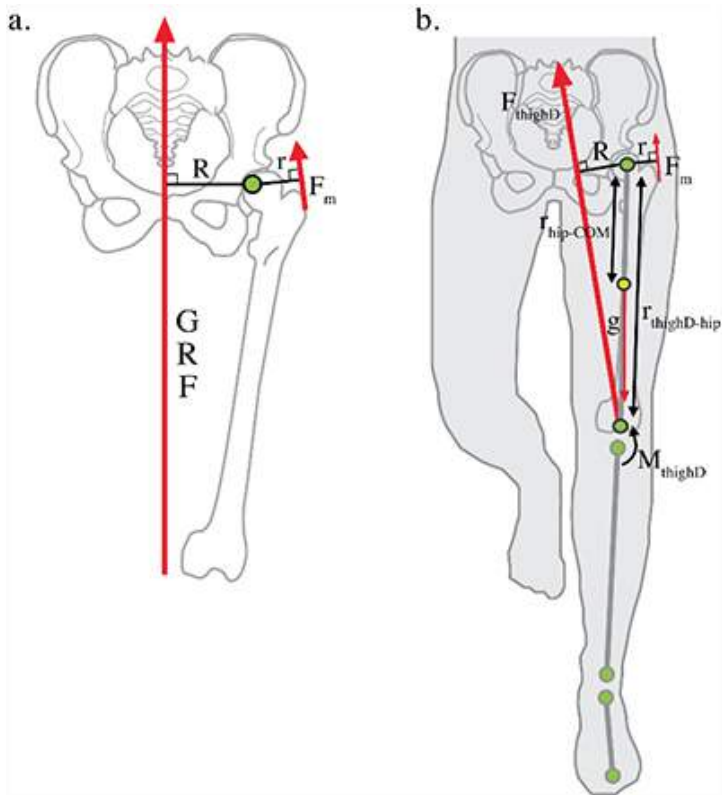
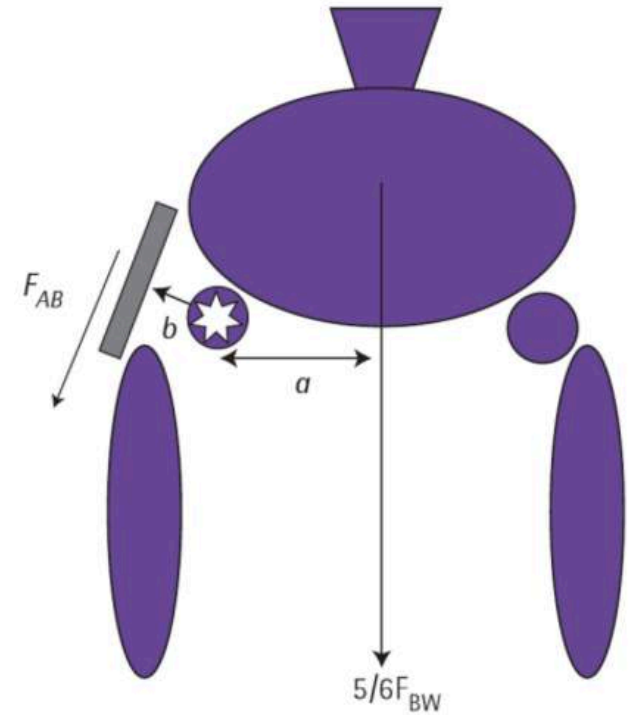
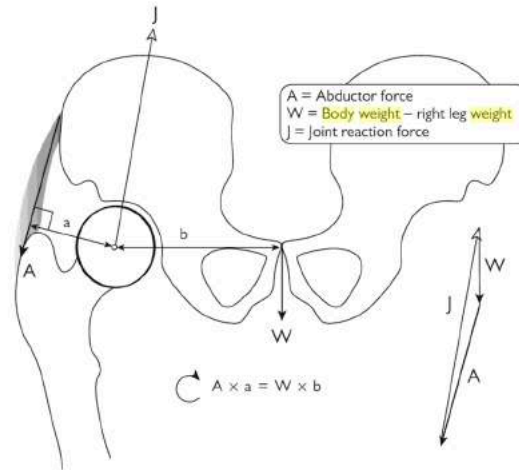
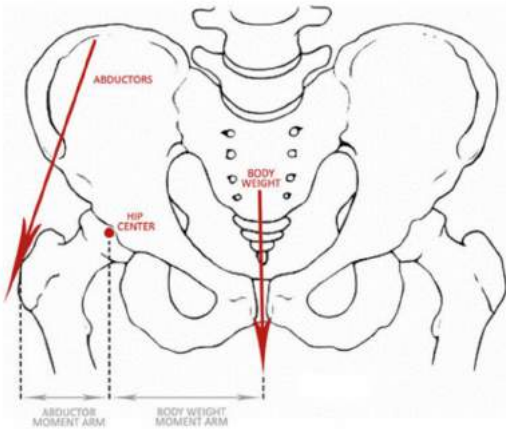

**POTENTIAL  
ANSWER**

Question: Can you draw a free body diagram of the hip joint?

- General assumptions
  - The body is in equilibrium
- Specific assumptions for hip joint
  - Single leg stance
  - Weight of one leg is 1/6th total body weight
  - Pubic symphysis
- Practice drawing out beforehand
- Rehearse your explanation as you go along
- Simplified diagram

# Hip Biomechanics

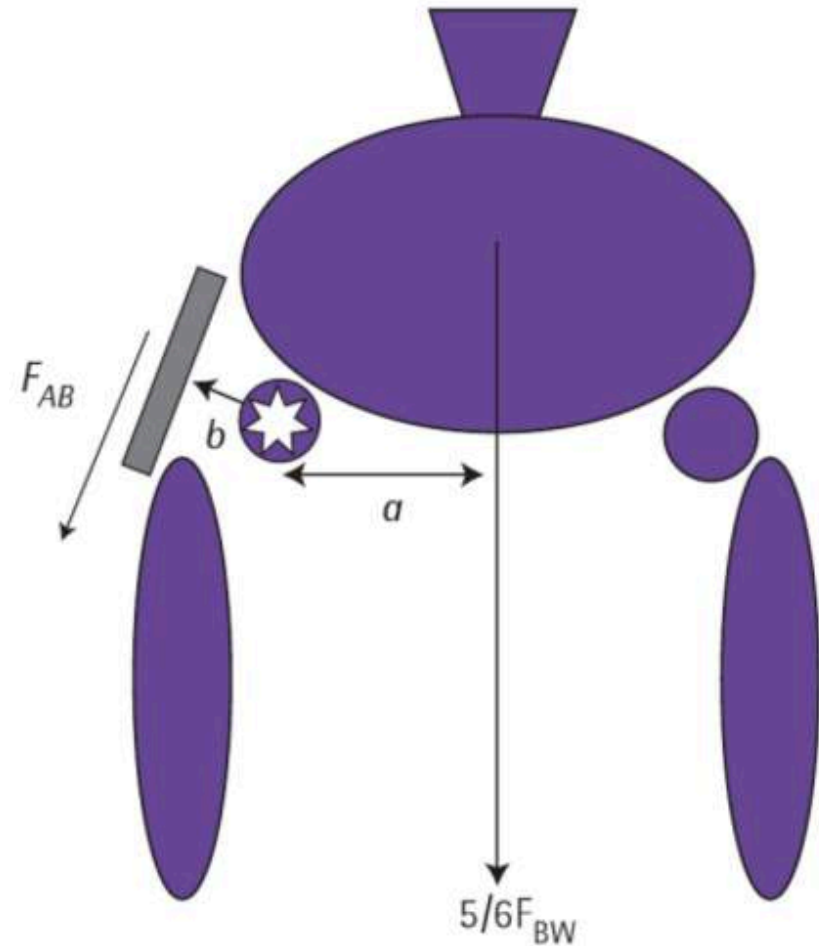
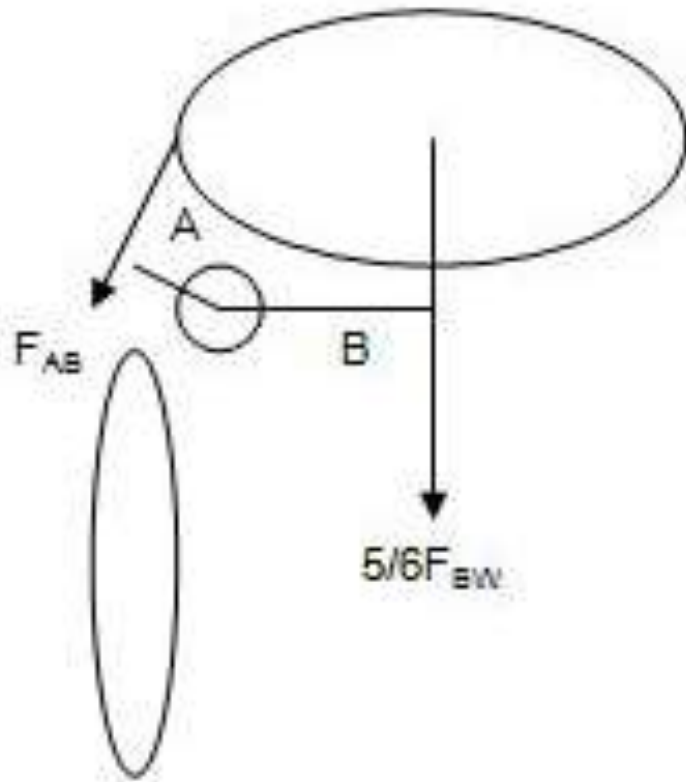

# Abductor muscle force

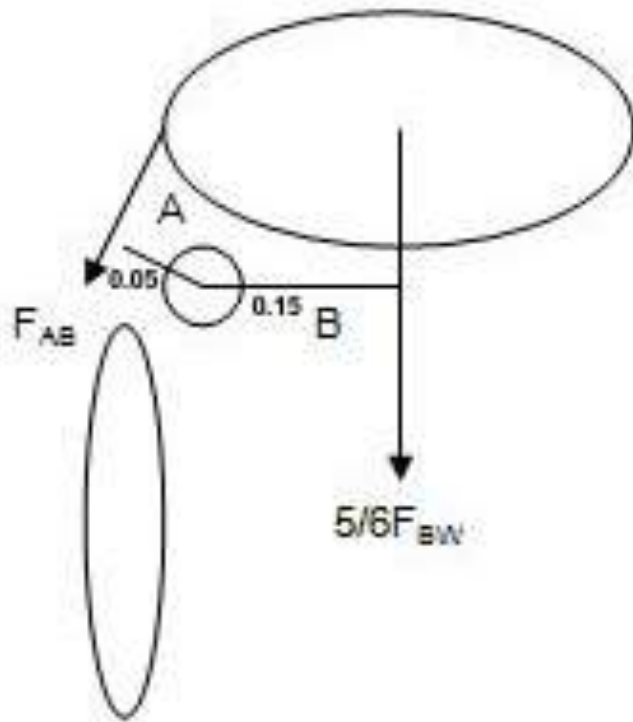

- $BW=600N(1 \text{ X limb}=1/6BW)$
- $A=0.05m$
- $B=0.15m$
- Clockwise moment =  
Anticlockwise moment
- $500 \times 0.15 = FAB \times 0.05$
- $FAB=1500N$

# Hip Biomechanics

- Do not assume abductor muscles act only in a vertical direction
- Split abductor into  $M_y$  and  $M_x$  components
- $\Sigma M = 0$
- $0.05M_y + 0.15W = 0$
- $M_y = 3W$
- $\Sigma F = 0$
- $R_y = M_y + W$
- $R_y = 4W$
- $R = R_y / (\cos 30 \text{ degrees})$

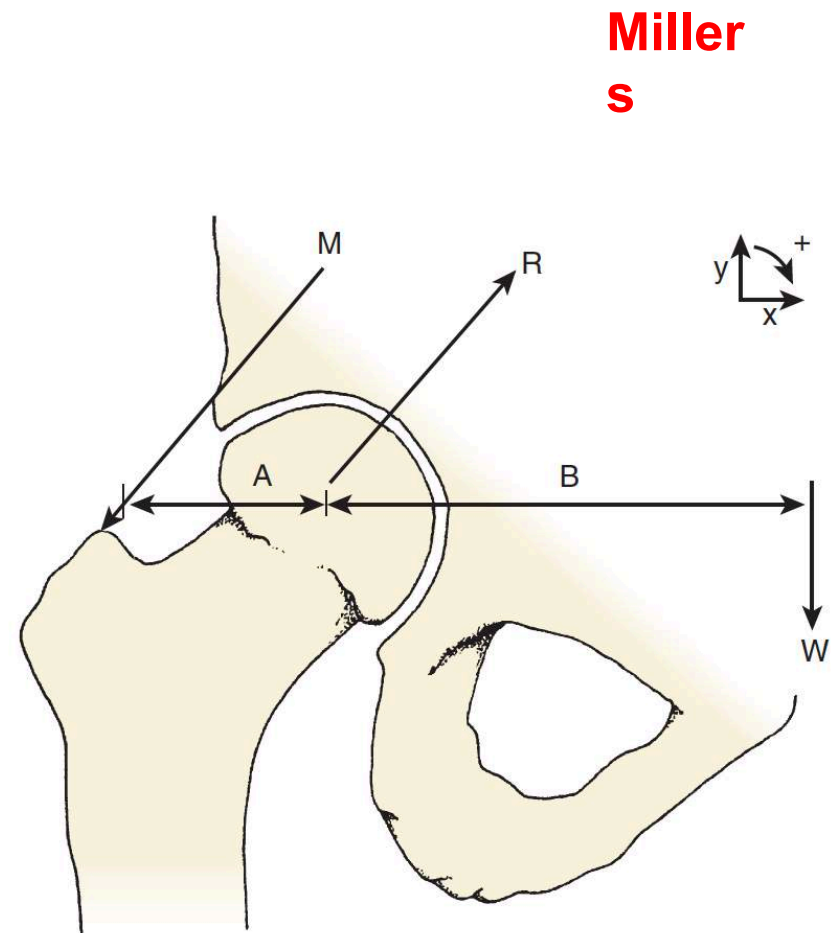

Postgraduate  
Orthopaedics

# Hip Biomechanics - cane

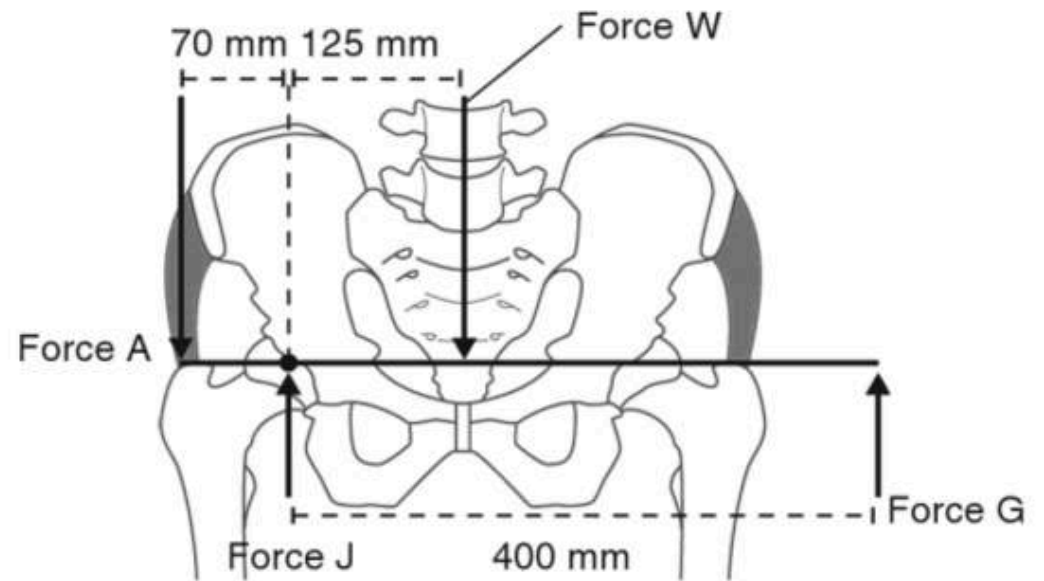
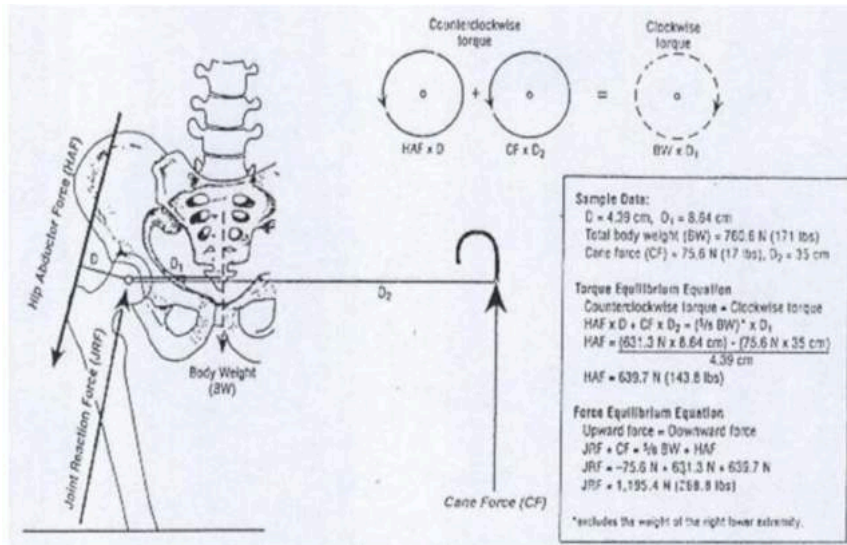
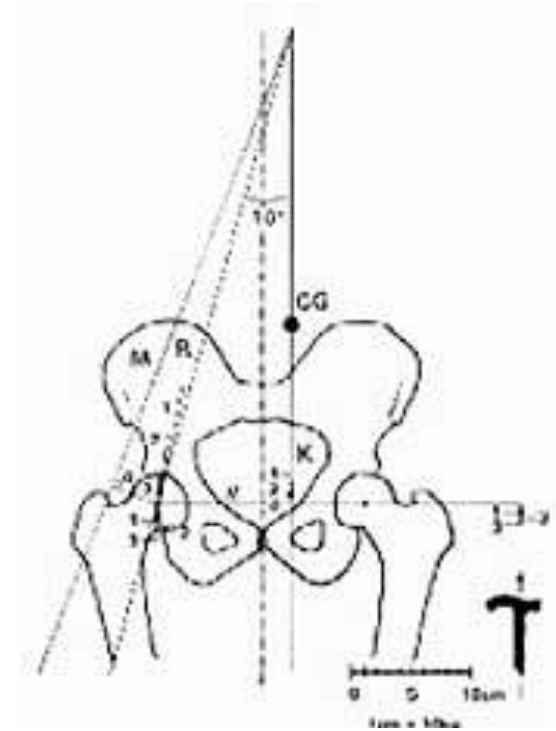
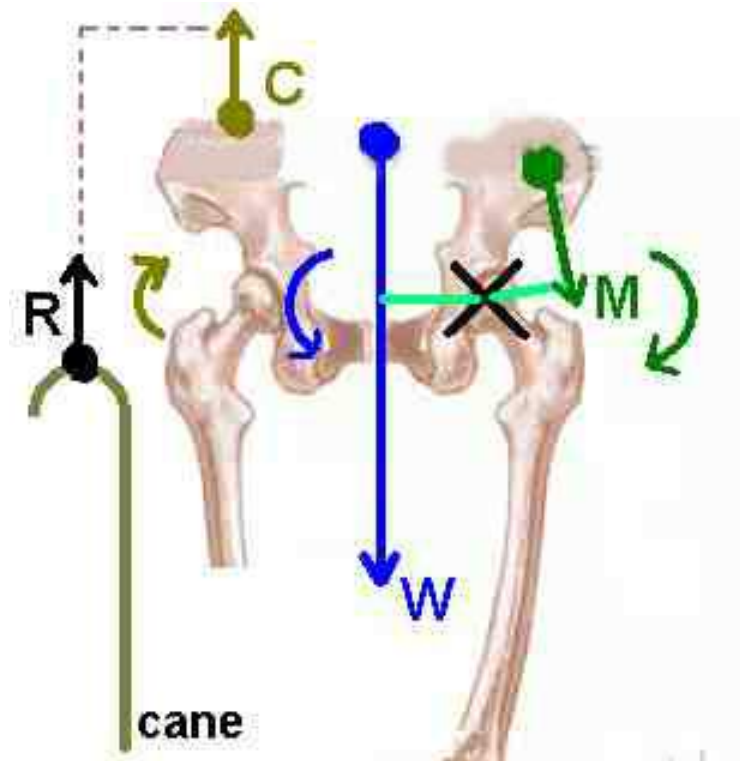

# Hip biomechanics - cane

- $BW = 600$
- $A = 0.05\text{m}$
- $B = 0.15\text{m}$
- $C = 0.45\text{m}$
- $F_{\text{STICK}} = 100\text{N}$

- Sum moments about the hip
- Clock wise =  $500 \times 0.15$
- Anticlockwise =  $F_{AB} \times 0.05 + 100 \times 0.60$
- $0.05 \times F_{AB} = 75 - 60$
- $F_{AB} = 15 / 0.05 = 300\text{ N}$

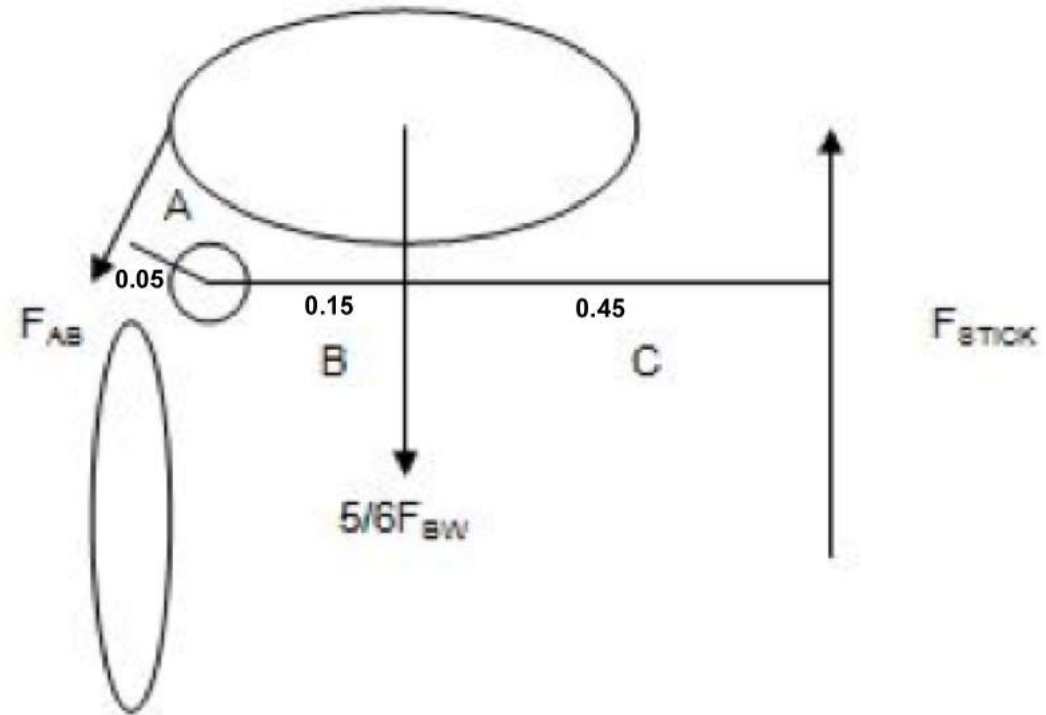

# Hip biomechanics - suitcase

- $BW = 600\text{N}$
- Weight of suitcase =  $250\text{N}$
- $A = 0.05\text{m}$
- $B = 0.15\text{m}$
- $C = 0.45\text{m}$
- Sum moments about the hip
- Clock wise moment =  $500 \times 0.15 + 250 \times 0.6$
- Anticlockwise moment =  $F_{AB} \times 0.05$
- $0.05F_{AB} = 75 + 150$
- $F_{AB} = 225 / 0.05 = 4500\text{ N}$

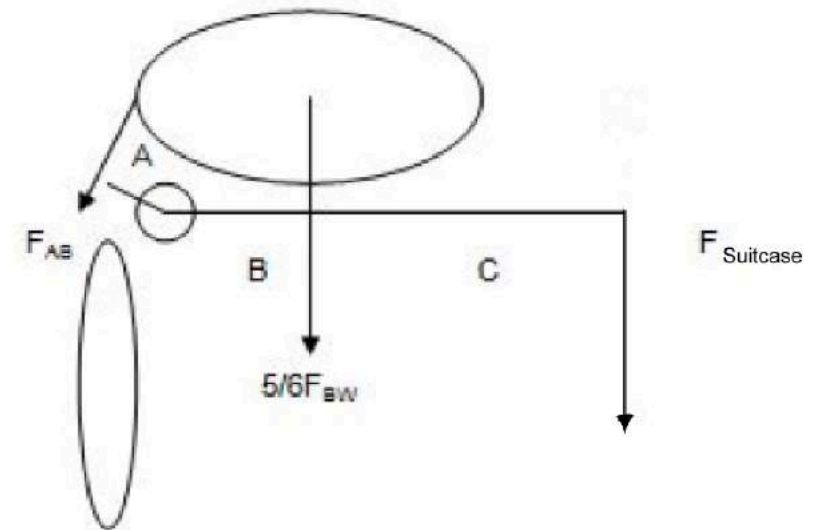
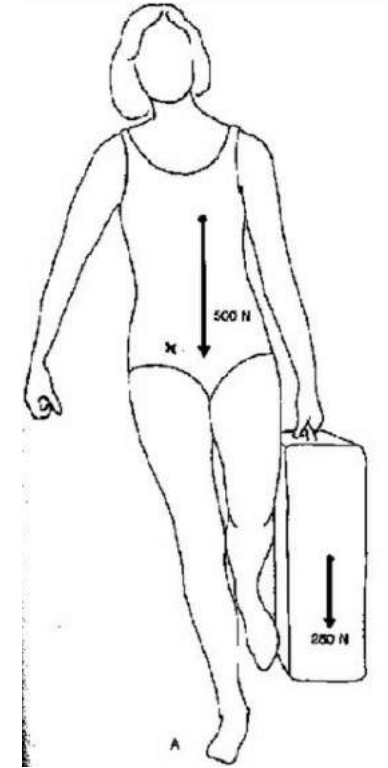



# Spine biomechanics at L5/S1

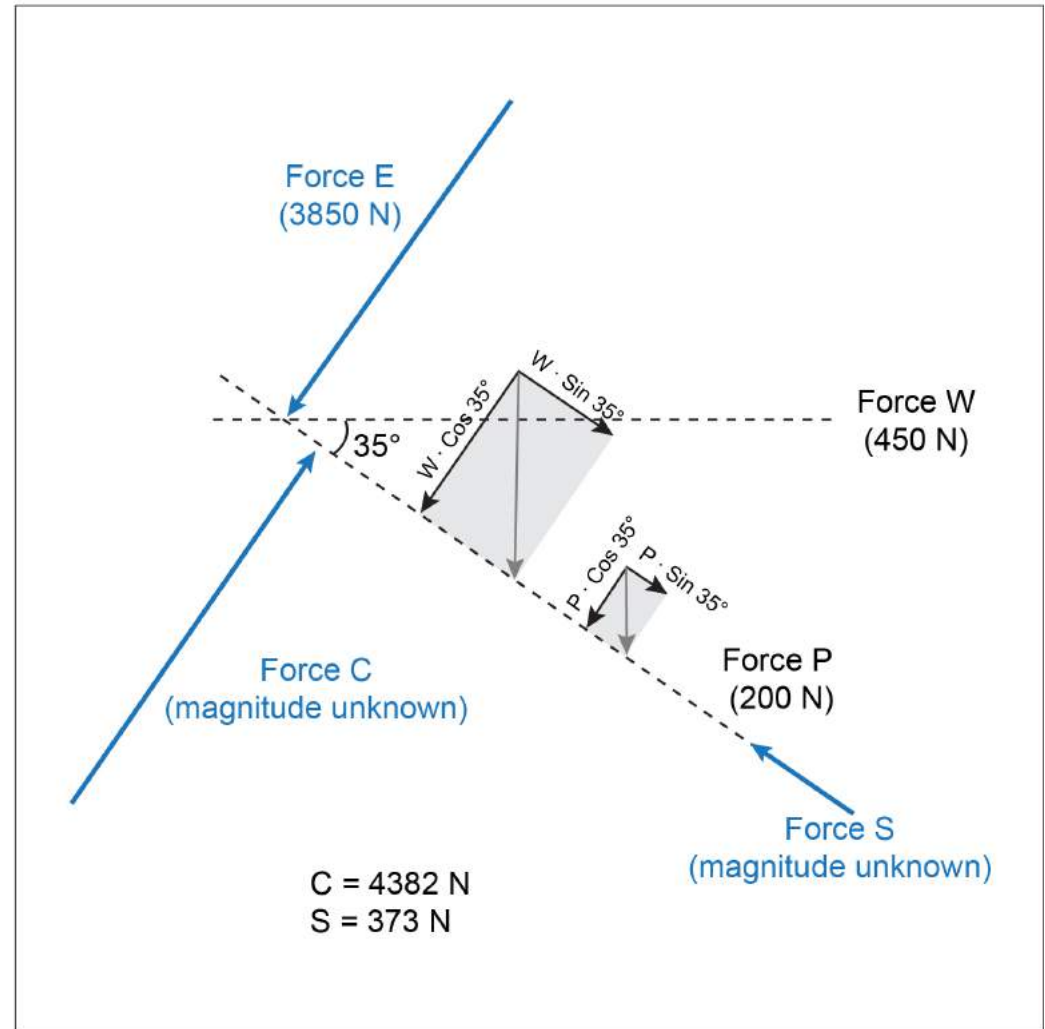
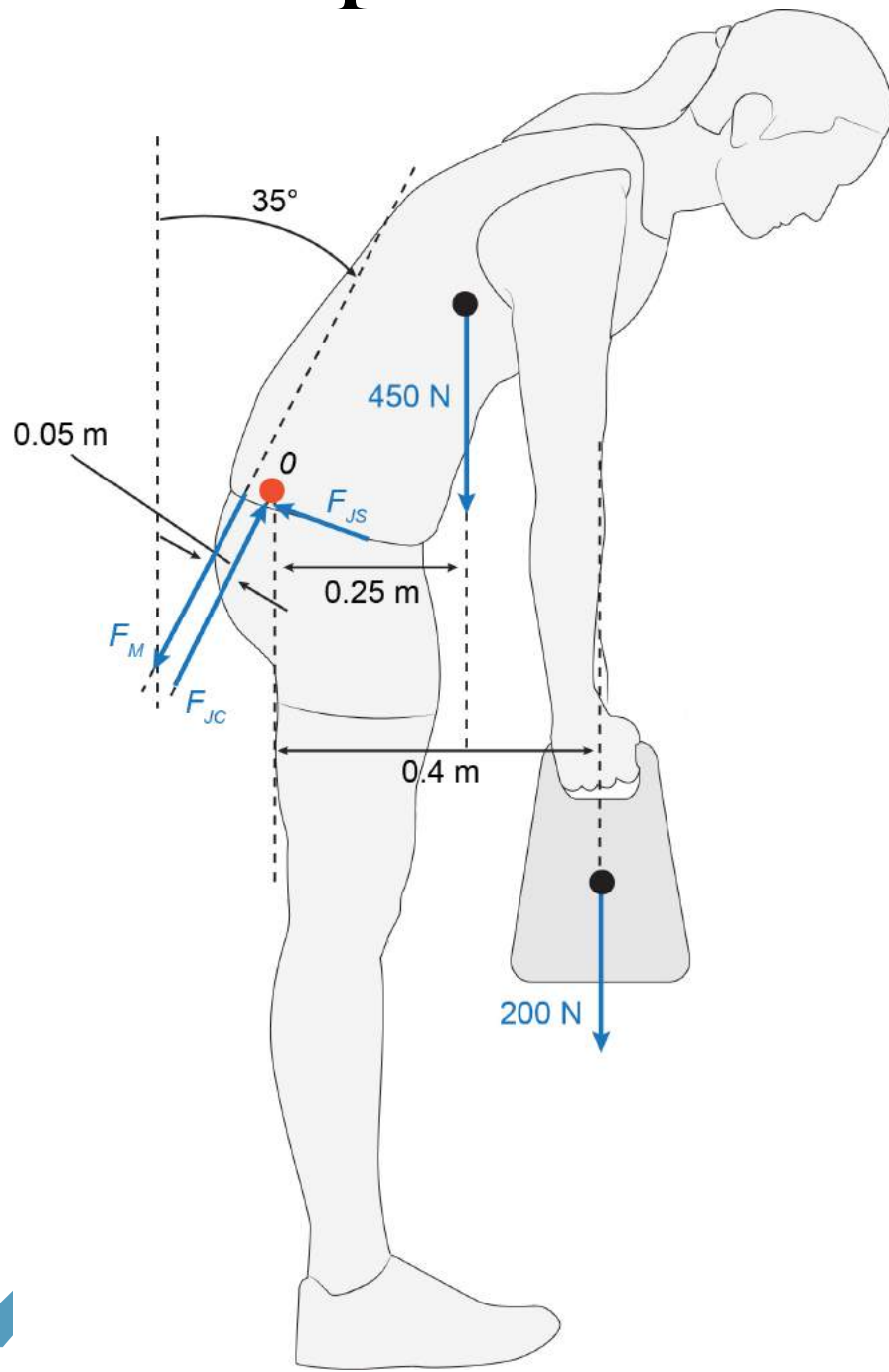

# Erector spinae muscle force

- $\Sigma M=0$
- $450\text{N} \times 0.25\text{m} + 200\text{N} \times 0.4\text{m} = \text{FES} \times 0.05\text{m}$
- $112.5\text{Nm} + 80\text{Nm} = \text{FES} \times 0.05\text{m}$
- $\text{FES} = 192.5\text{Nm}/0.05\text{m}$

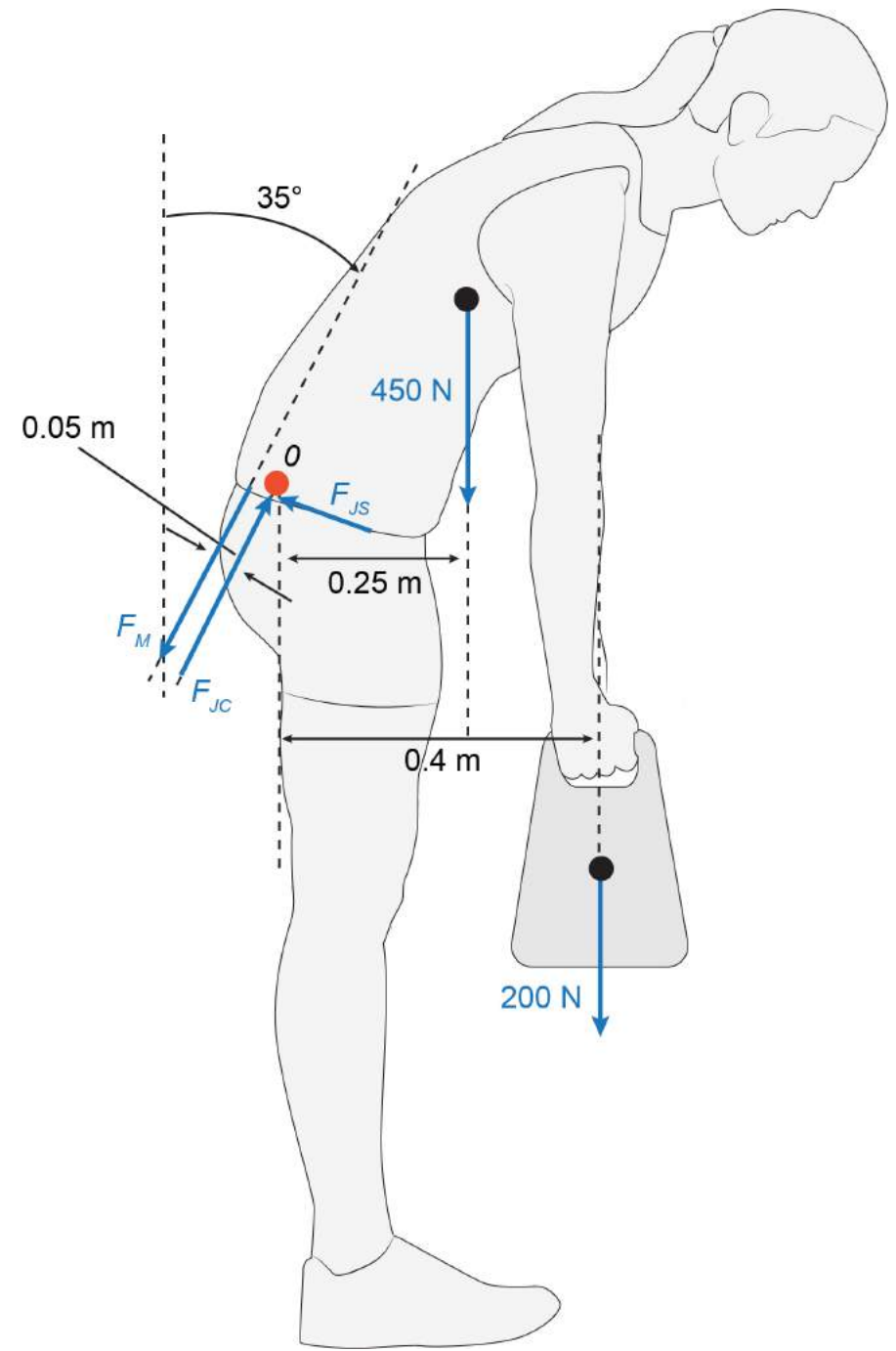

# Shear/compressive forces at L5/S1

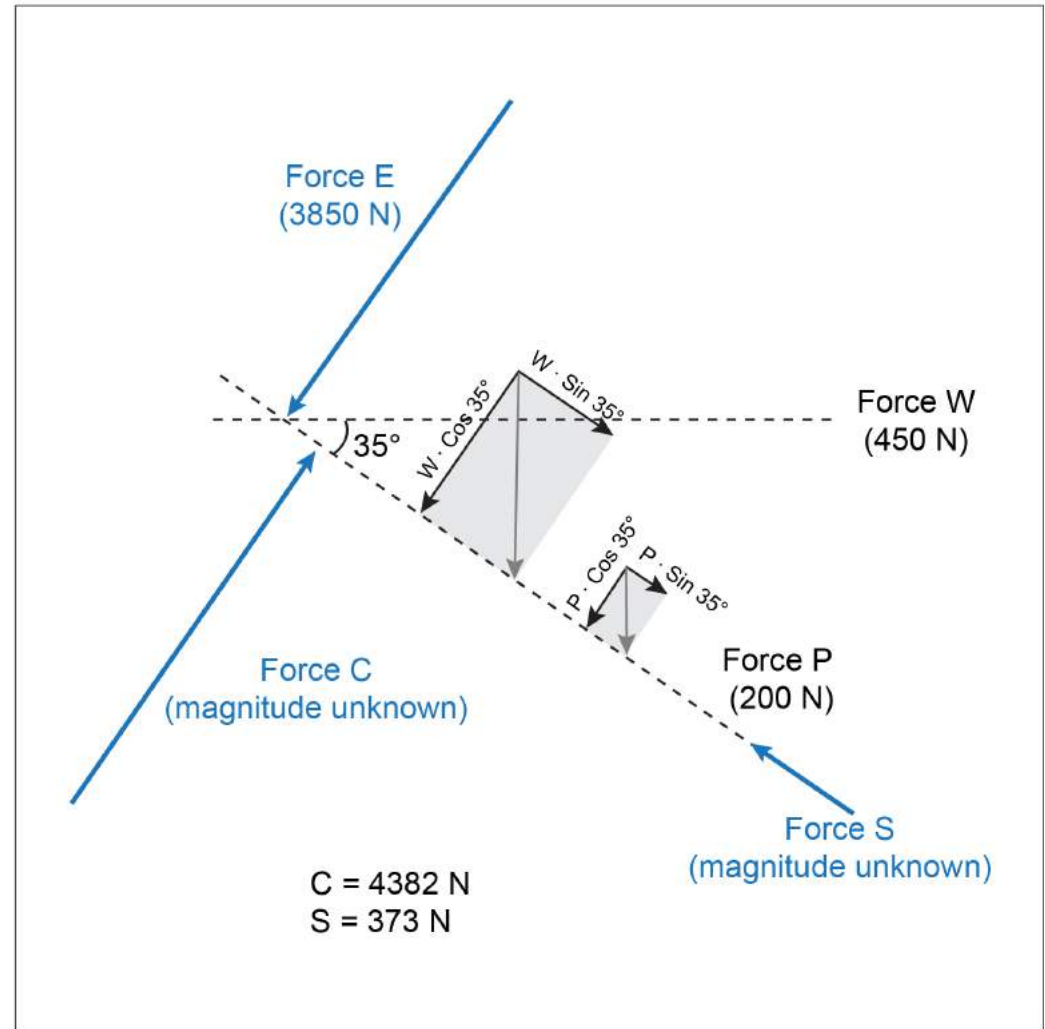
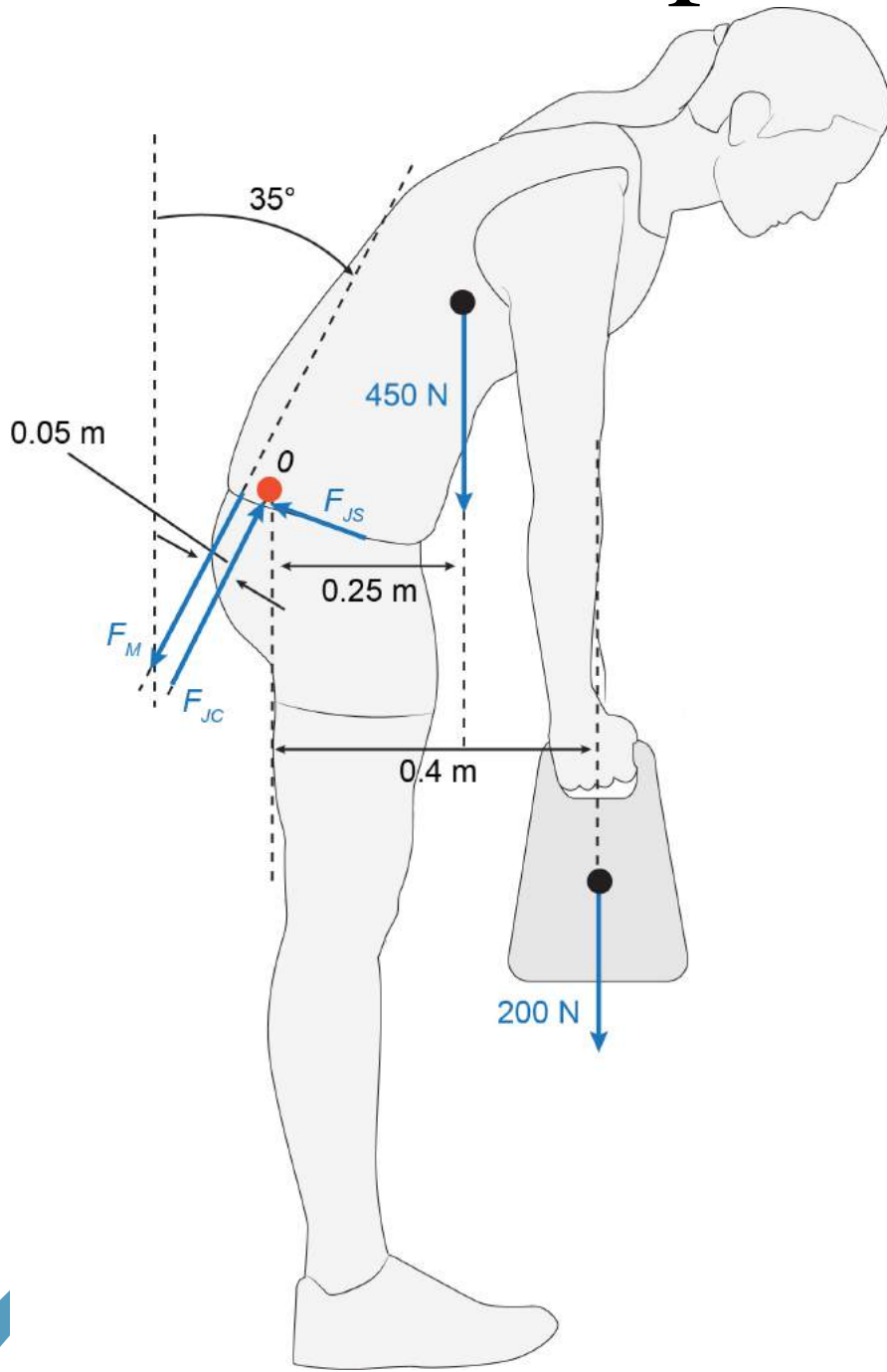

# Shear/compressive forces at L5/S1

- $\Sigma F=0$
- $C = 450\cos35 + 200\cos35 + 3850\text{N}$
- $C = 368.5\text{N} + 163.8\text{N} + 3850\text{N}$
- $C = 4382.3\text{N}$
- $S = 450\sin35 + 200\sin35$
- $S = 373\text{N}$

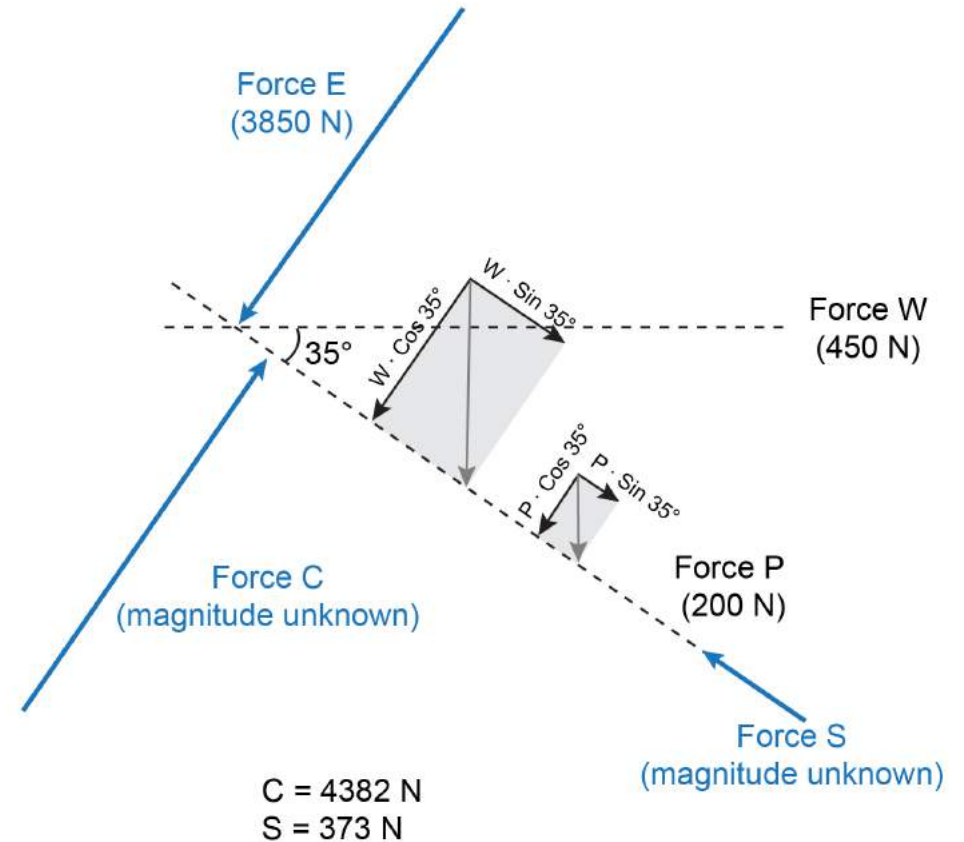

Thank you  
for listening